

Ravenna Hub

1 terminal autobus di linea e bus turistici 2 uscita sottopasso urbano Parco Farini - Piazza A.Moro 3 biglietteria/info point 4 rampa di accesso al parcheggio coperto sopra via Darsena 5 nuova viabilità 6 edificio Ex Dogana 7 sottopasso ferroviario Stazione - Darsena 8 depositi e magazzini 9 rampa ciclopeditonale di accesso ai livelli superiori 10 Piazza Darsena 11 Moro di Venezia 12 scale di collegamento binari - Belvedere 13 Parco Farini 14 nuovo edificio Parco Farini 15 rampa ciclopeditonale di accesso al Belvedere 16 ascensori di collegamento Piazza Darsena e Aldo Moro - parcheggio - Belvedere 17 parcheggio coperto 18 Playground 19 Piazza Belvedere 20 punto panoramico 21 passerella ciclopeditonale 22 palestra di arrampicata 23 stazione ferroviaria 24 Darsena PopUp

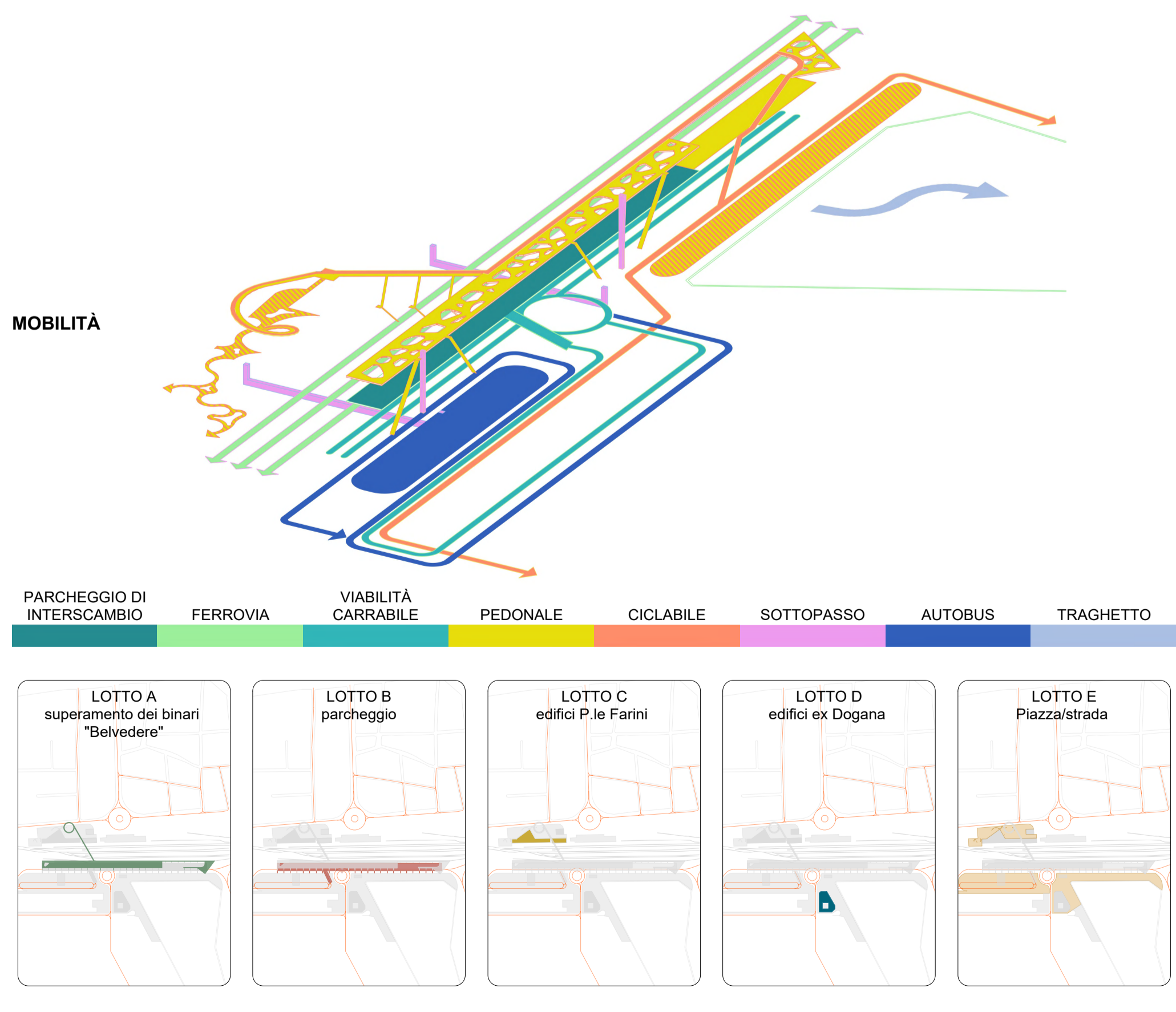

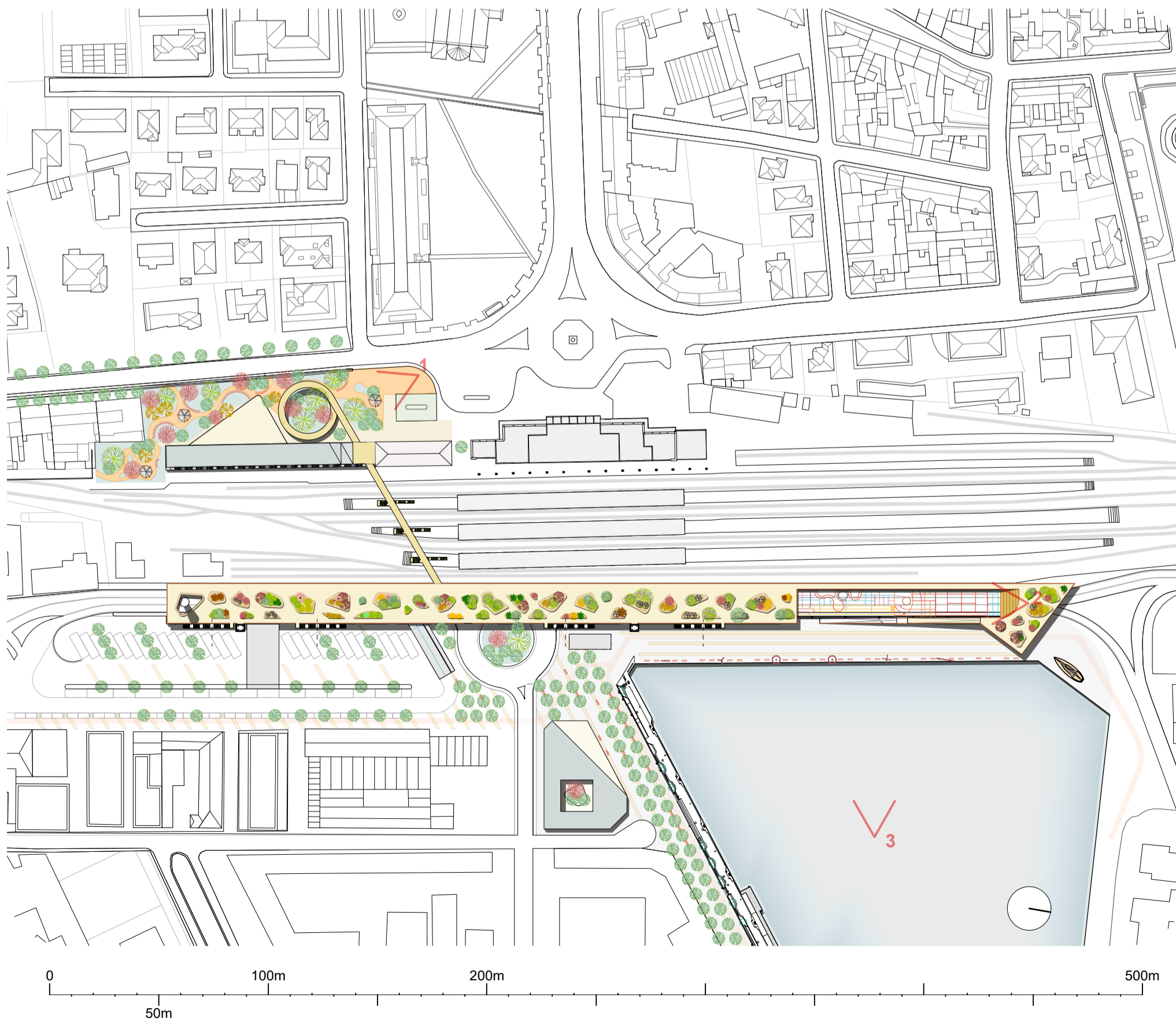
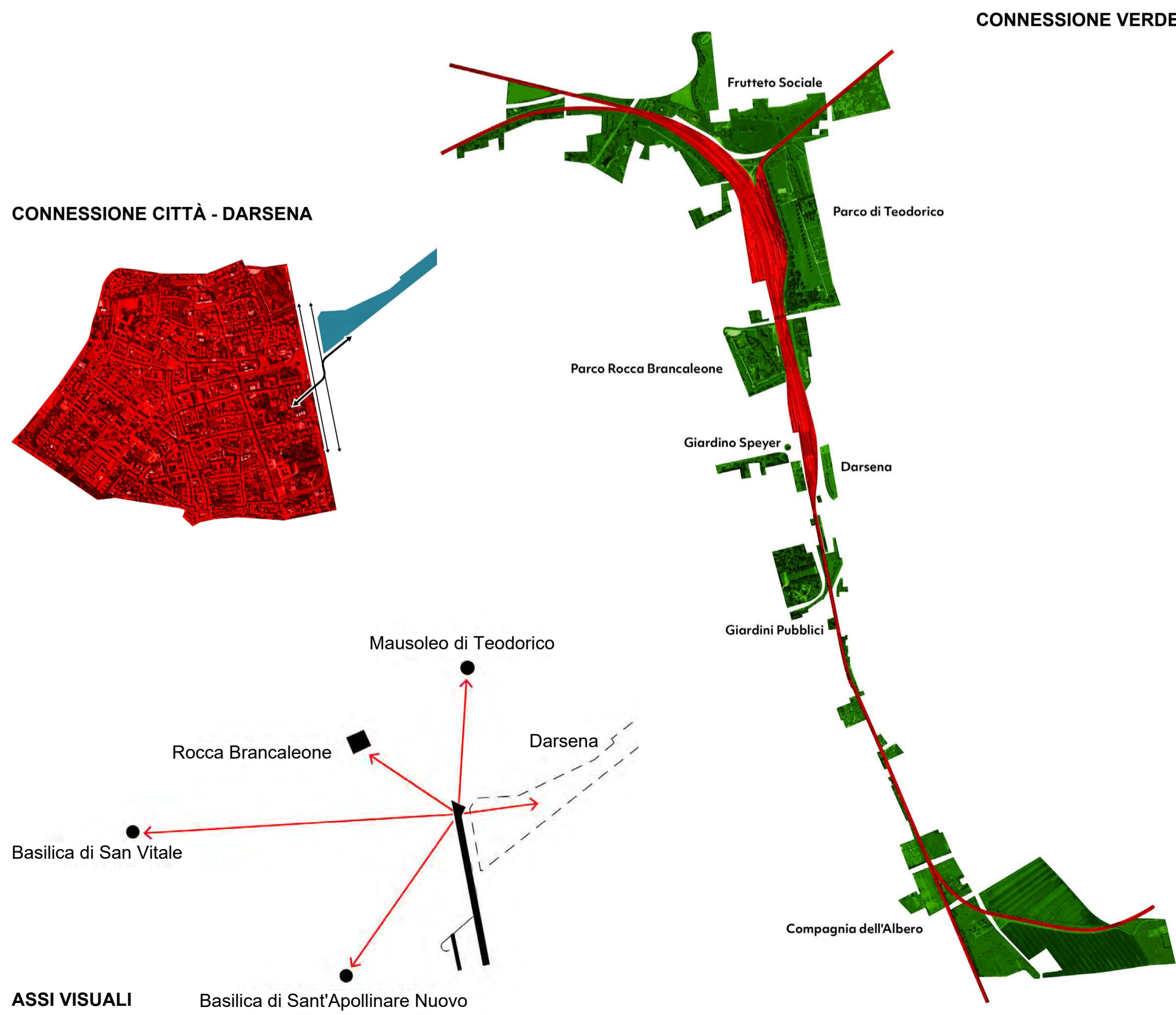
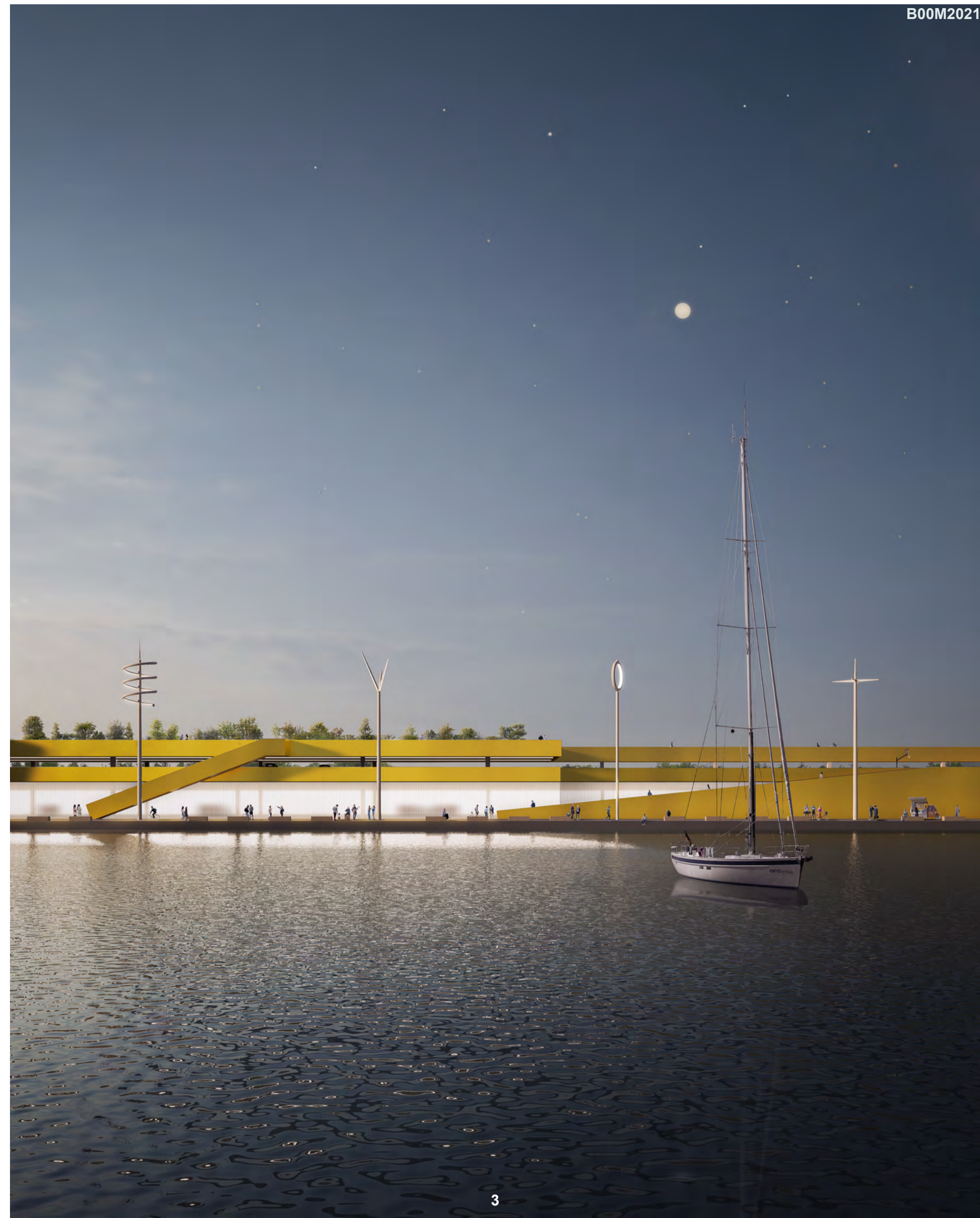
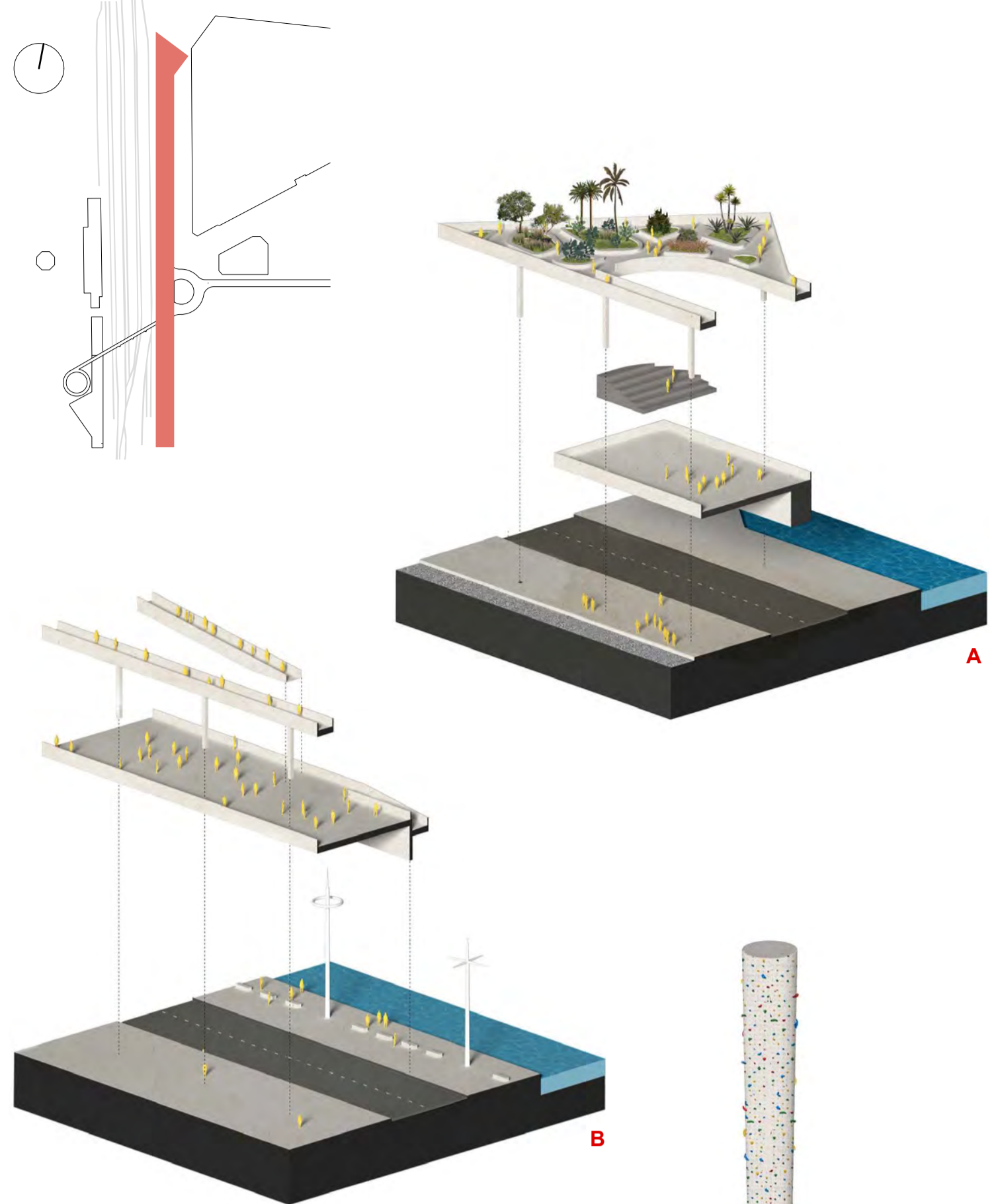

STRALCI TIPOLOGICI DELLA STECCA PARCHEGGIO

A
il punto panoramico in testa al Belvedere, la tribuna e la Playground in continuità con il parcheggio coperto

B
le passerelle di collegamento tra il Belvedere e la Playground, nuova Piazza Darsena

C
il Belvedere e la palestra di arrampicata, il parcheggio coperto sopra Via Darsena

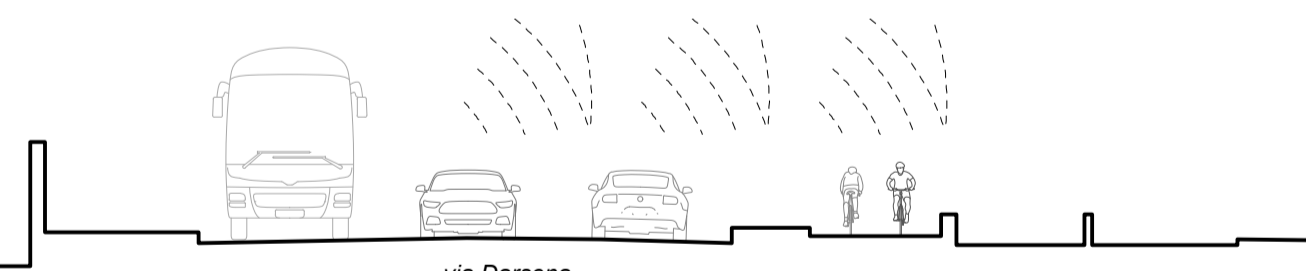

sezione tipologica stato attuale

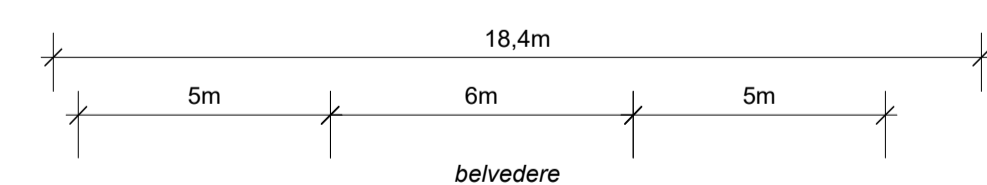

belvedere

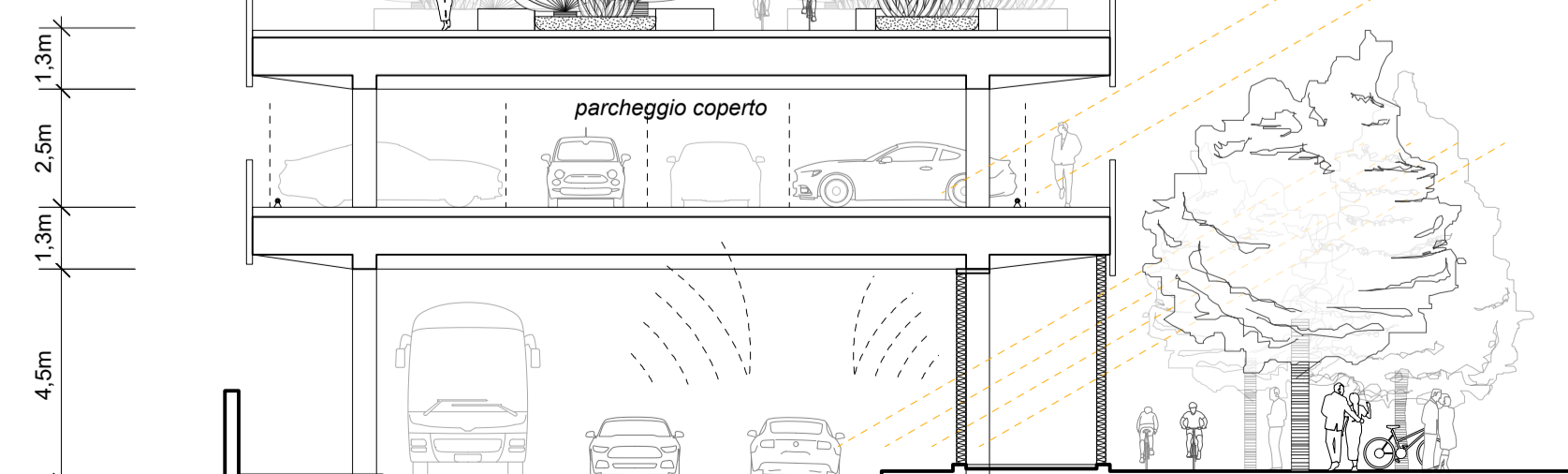

sezione tipologica di progetto

PIANO SECONDO +9,60 m

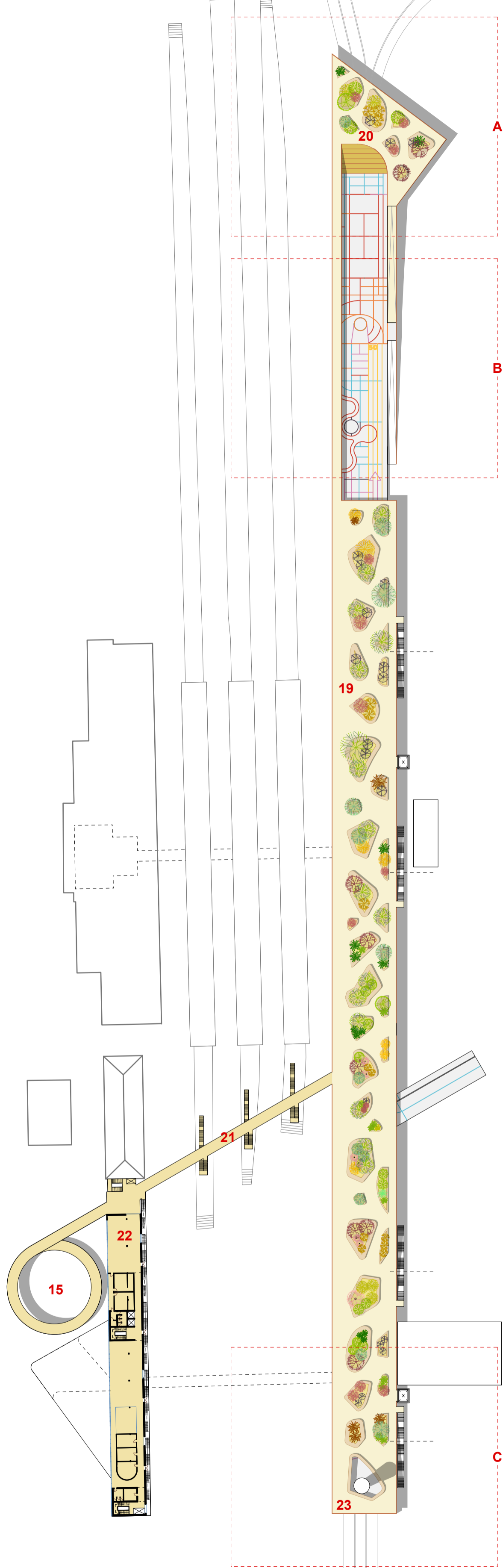

PIANO PRIMO +5,80 m

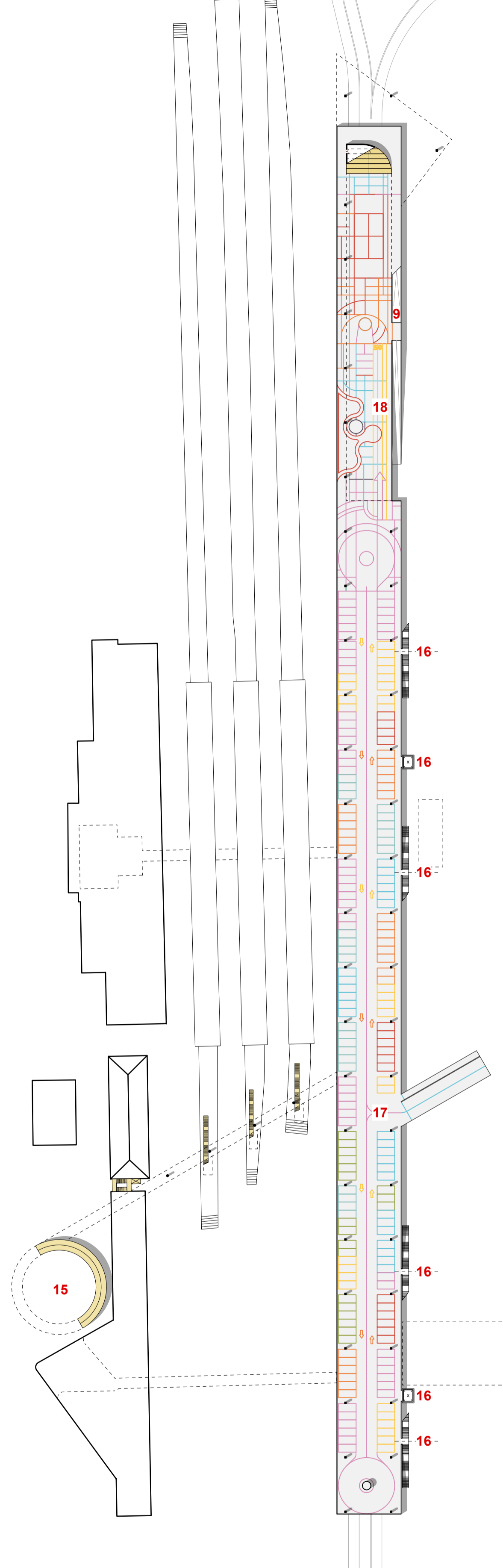

PIANO TERRA +0,00 m

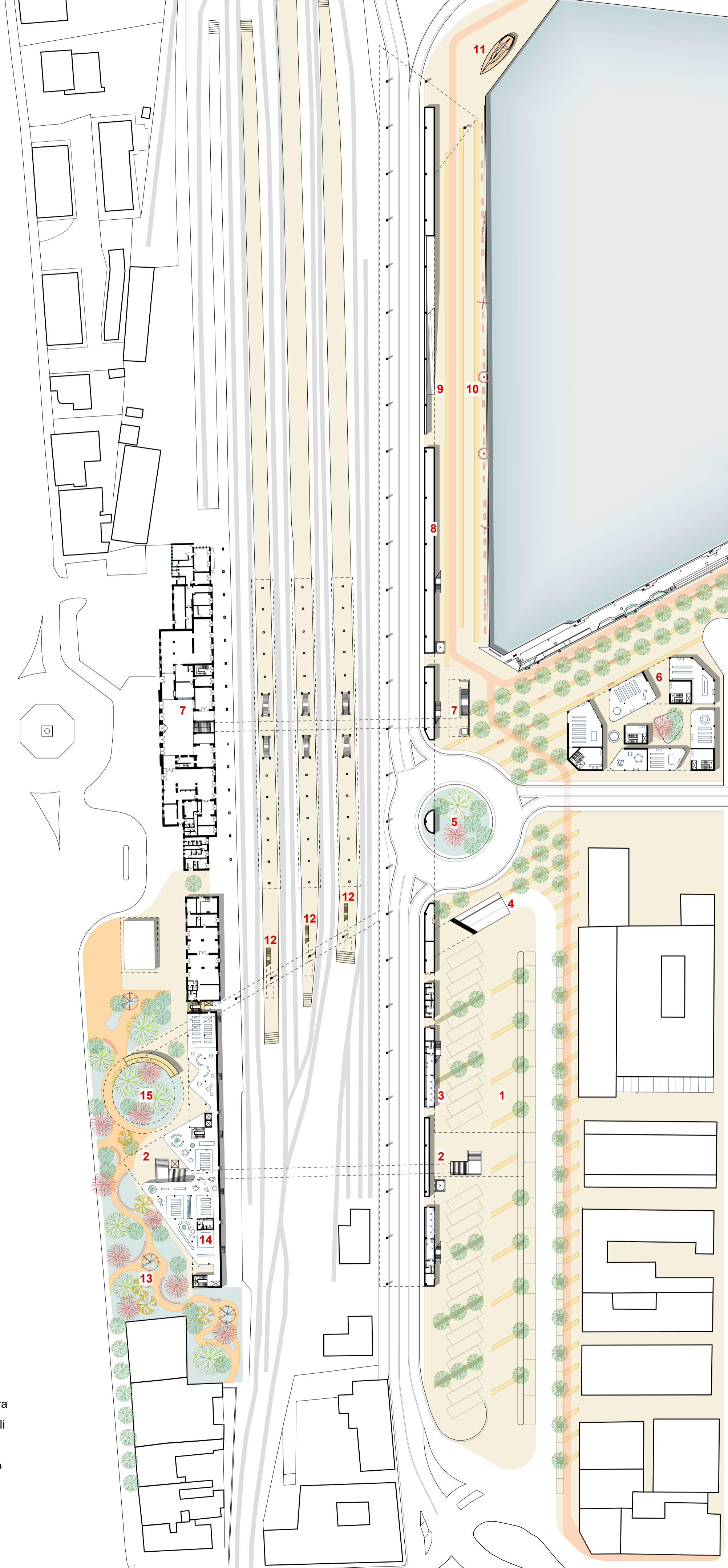

- 1** terminal autobus di linea e bus turistici
- 2** sottopasso urbano Parco Farini - Piazza A.Moro
- 3** biglietteria/info point
- 4** rampa di accesso al parcheggio coperto sopra via Darsena
- 5** nuova viabilità
- 6** edificio Ex Dogana
- 7** sottopasso ferroviario Stazione - Darsena
- 8** depositi e magazzini
- 9** rampa ciclopedonale di accesso ai livelli superiori
- 10** Piazza Darsena
- 11** Moro di Venezia
- 12** scale di collegamento binari - Belvedere
- 13** Parco Farini
- 14** nuovo edificio Parco Farini
- 15** rampa ciclopedonale di accesso al Belvedere
- 16** scale e ascensori di collegamento Piazza Darsena e Piazza Aldo Moro- parcheggio - Belvedere
- 17** parcheggio coperto
- 18** Playground
- 19** Piazza Belvedere
- 20** punto panoramico
- 21** passerella ciclopedonale
- 22** piano servizi nuovo edificio Parco Farini
- 23** palestra di arrampicata

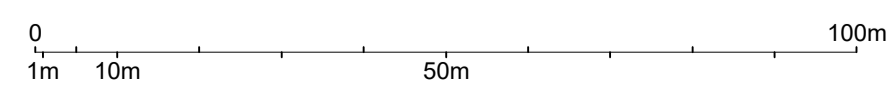

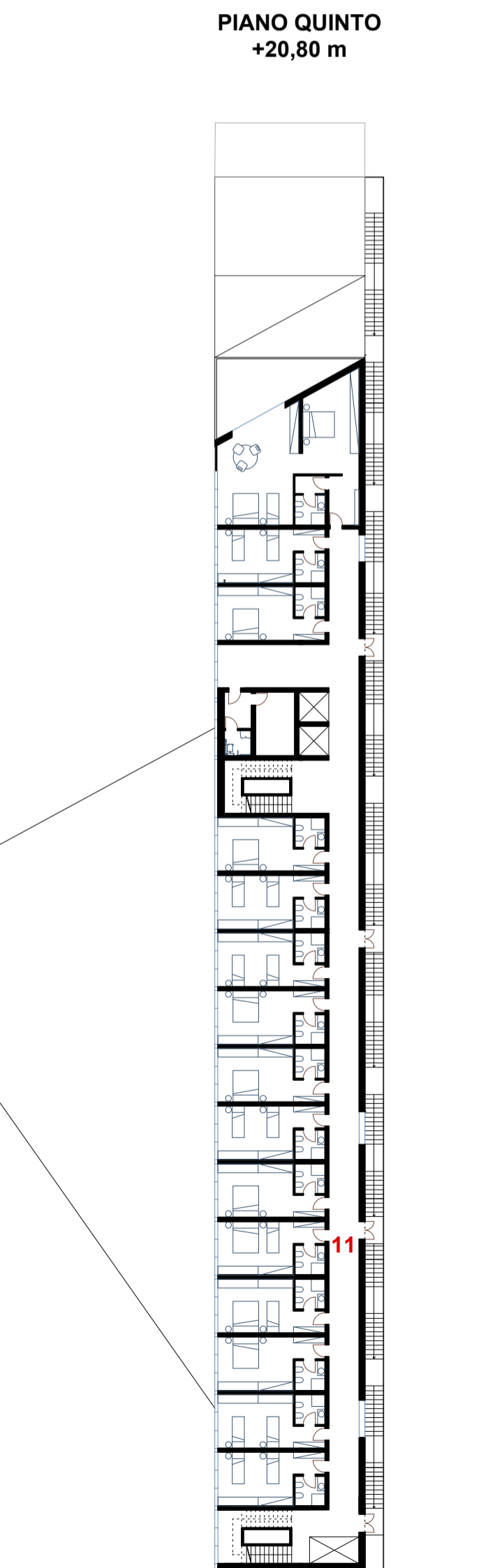
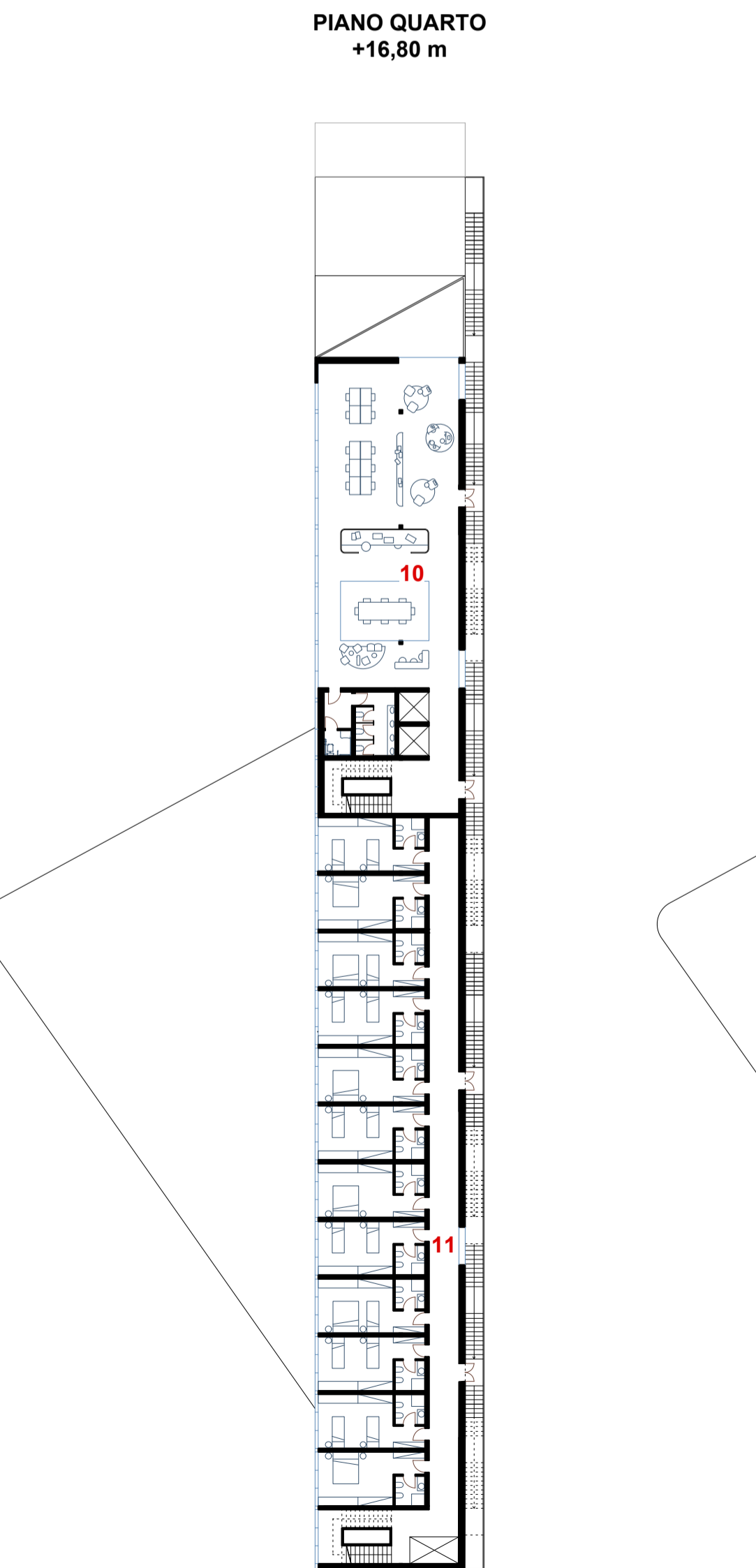
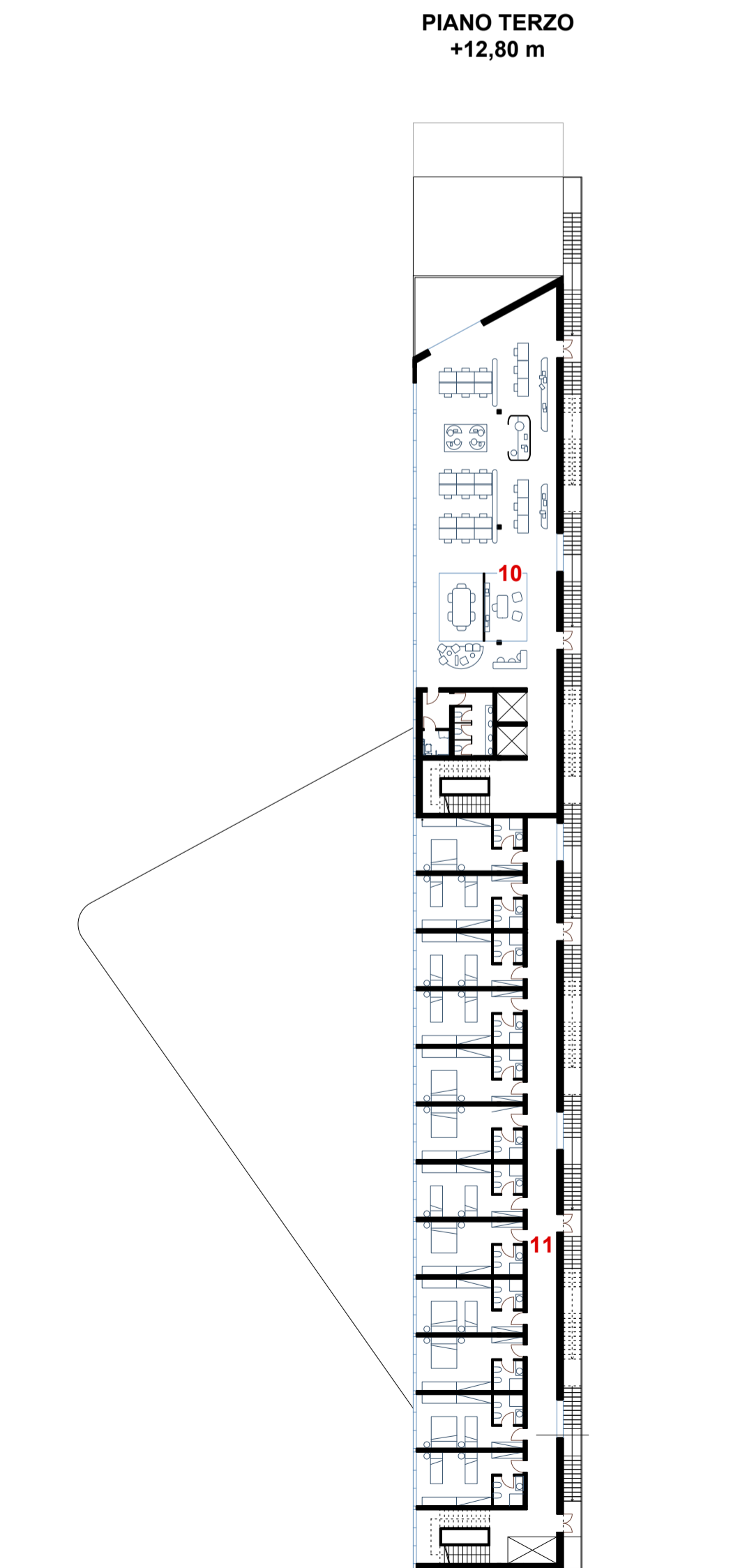
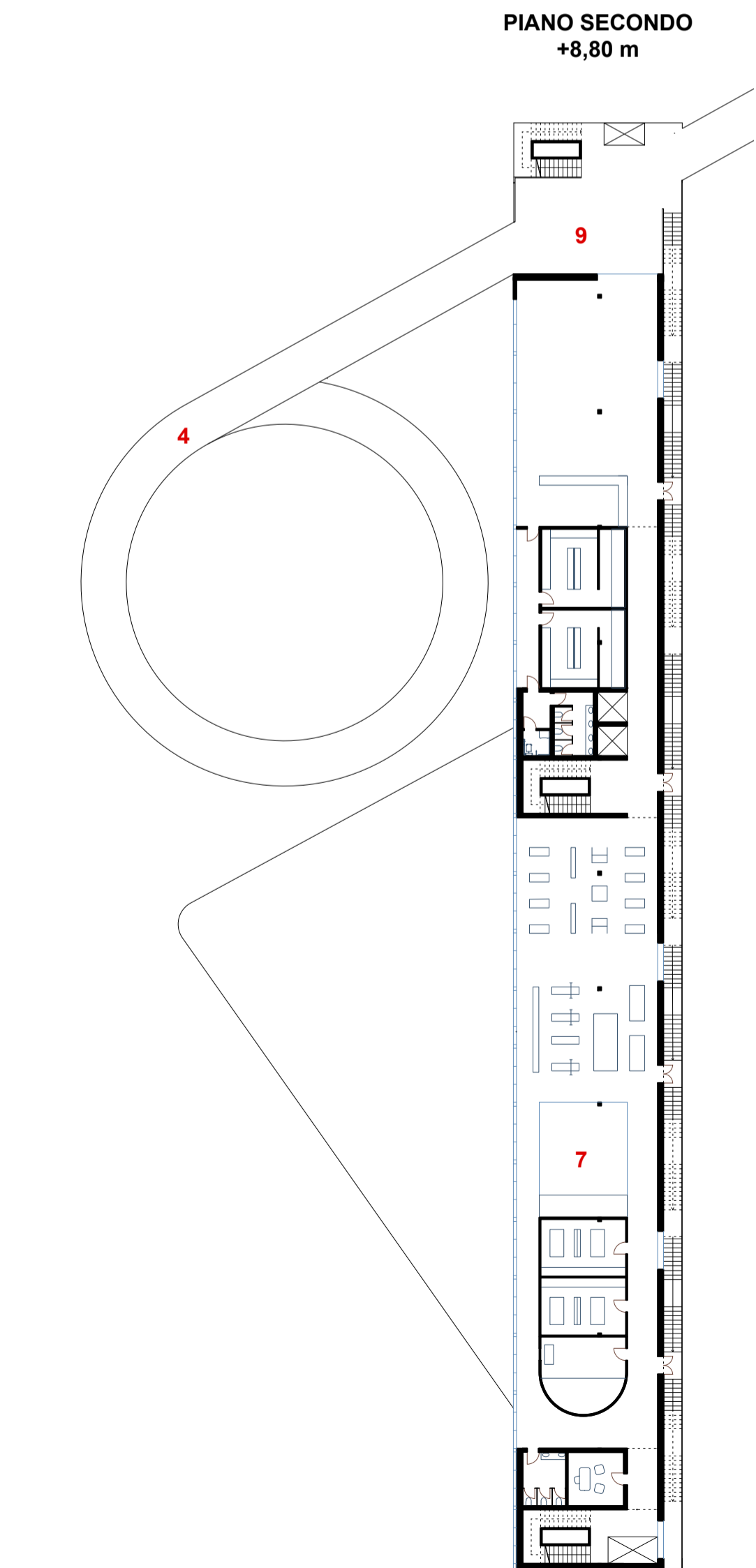
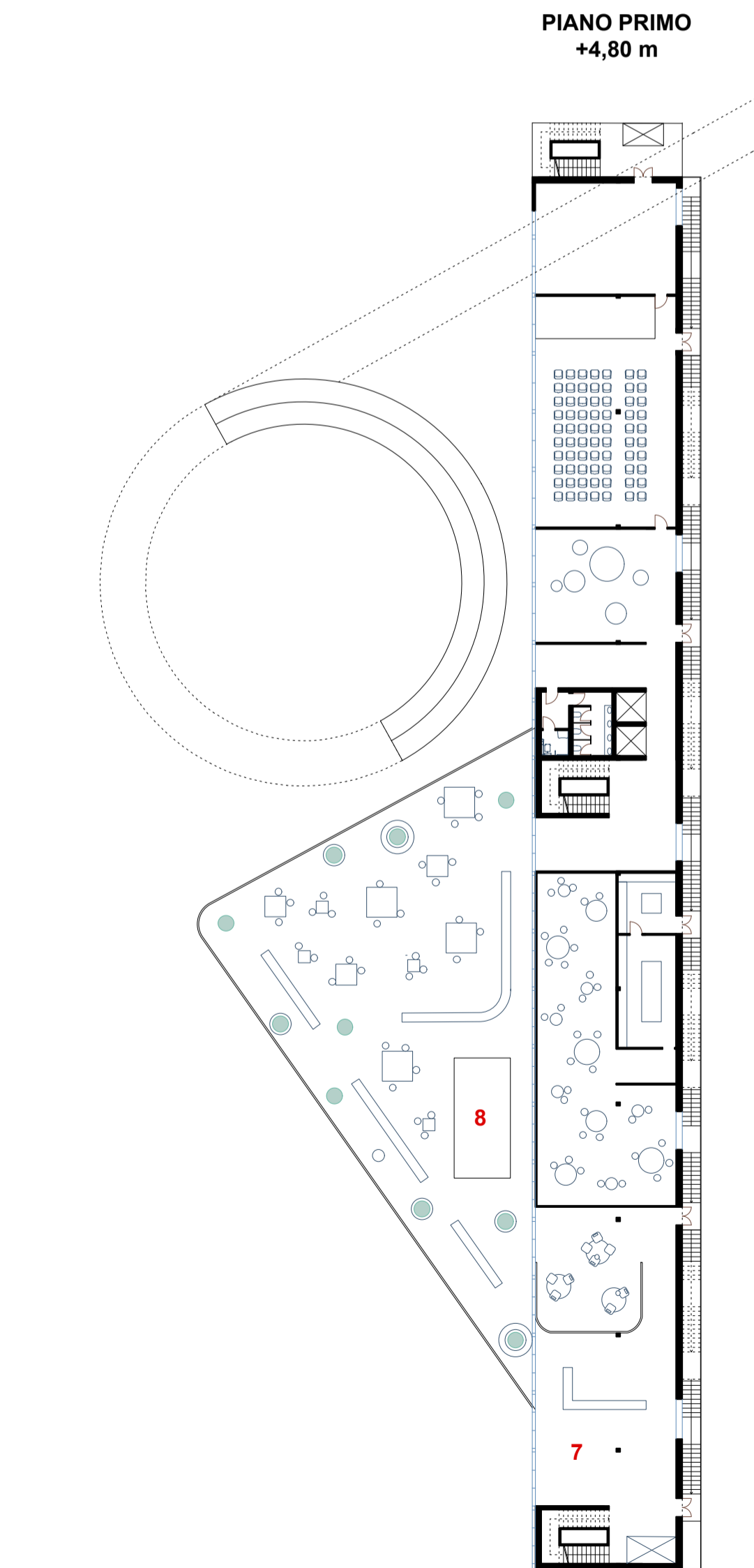
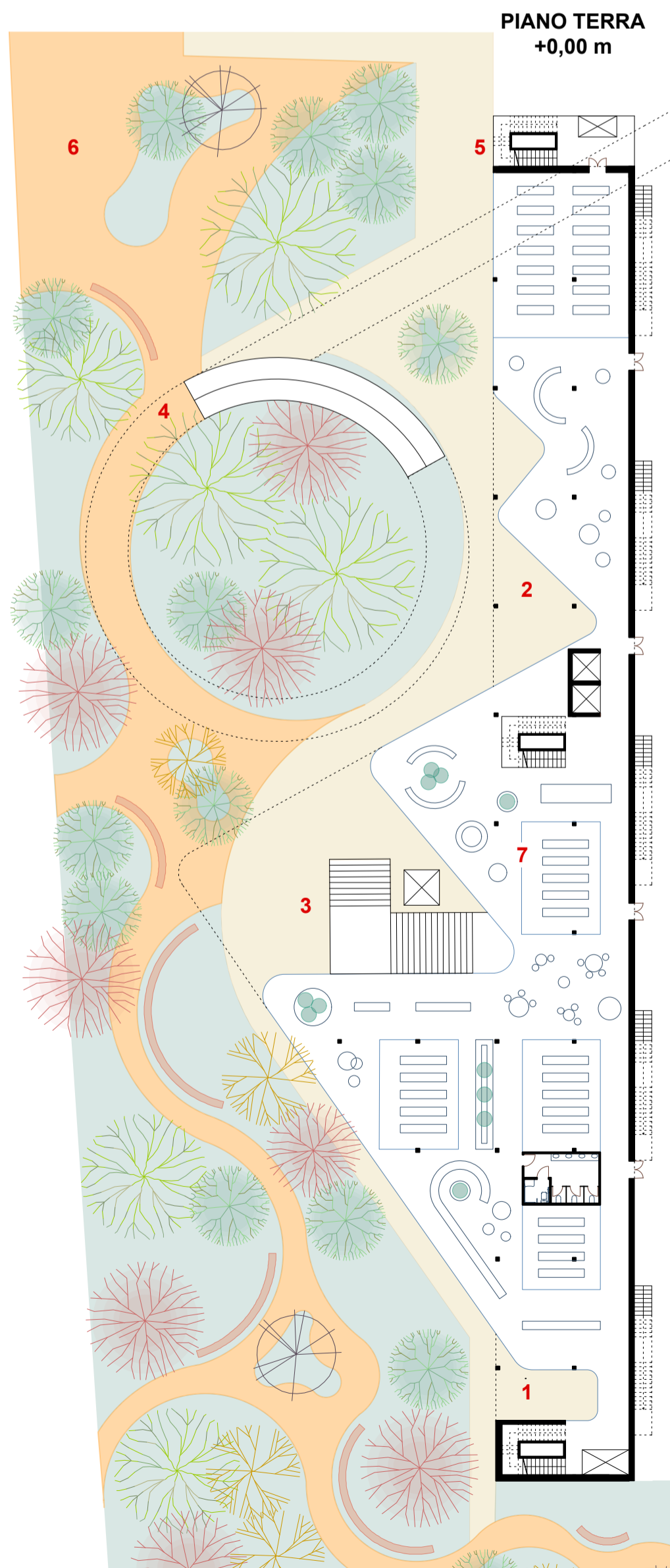
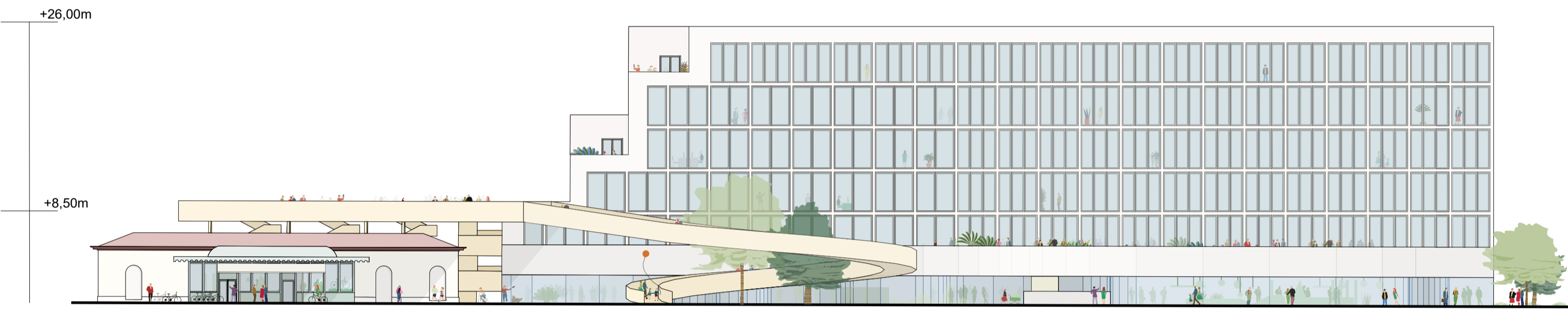
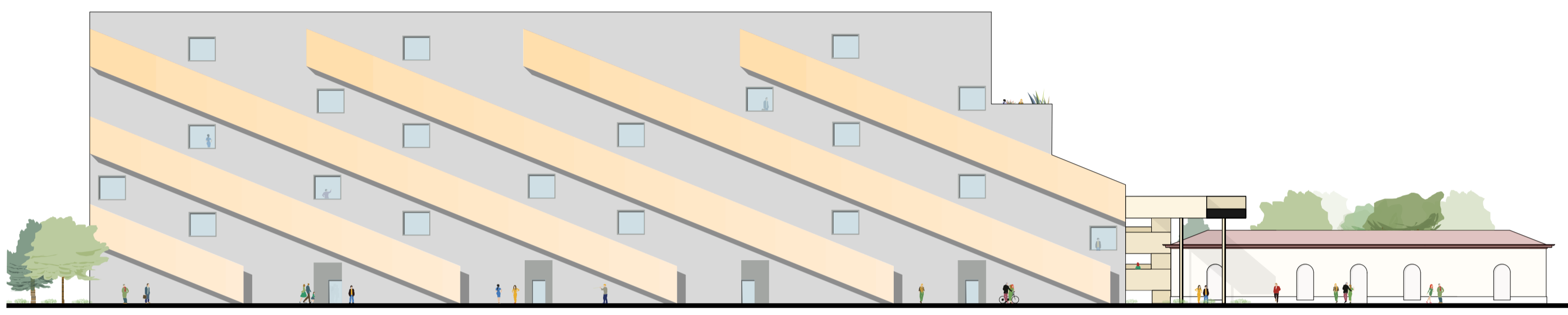
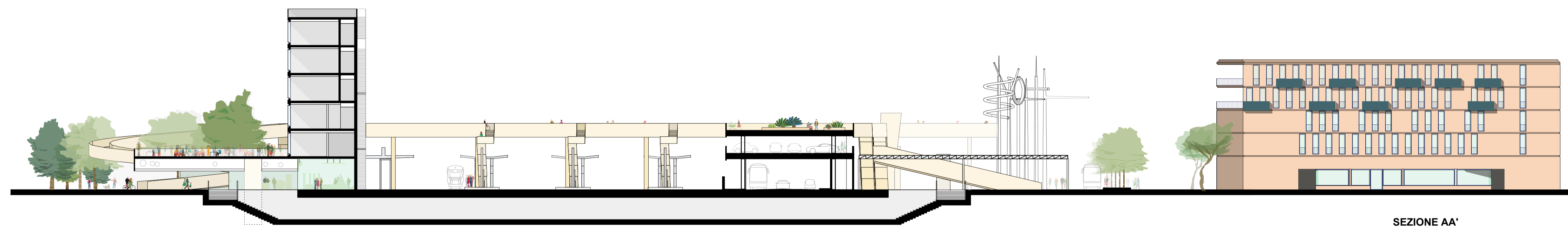
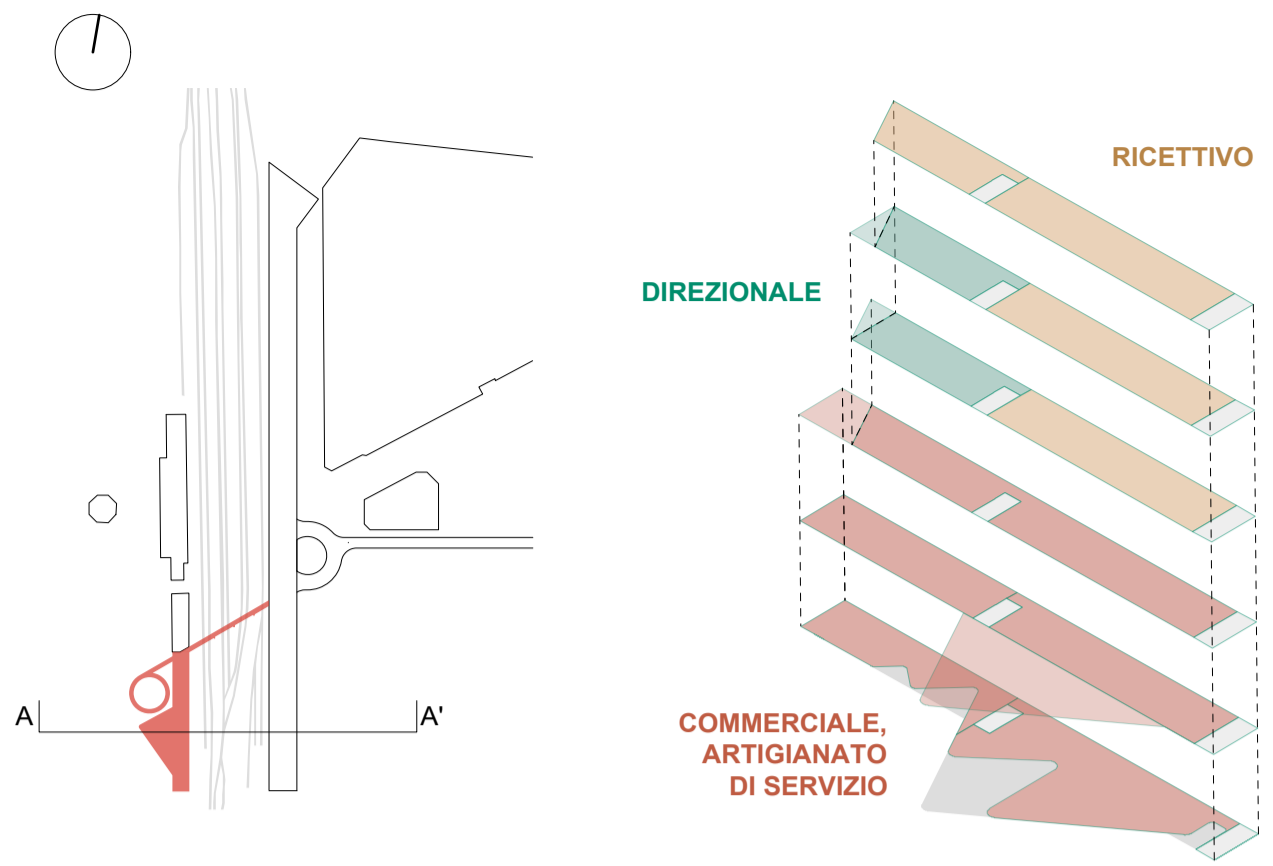

1 ingresso ricettivo 2 ingresso direzionale 3 sottopasso urbano Parco Farini - Piazza A.Moro 4 passerella ciclopedonale 5 rampe e ascensori di collegamento Piazza Darsena - parcheggio - Belvedere 6 Parco Farini 7 spazi commerciali e artigianato di servizio 8 terrazza 9 accesso rampa ciclopedonale - nuovo edificio Parco Farini 10 direzionale 11 ricettivo

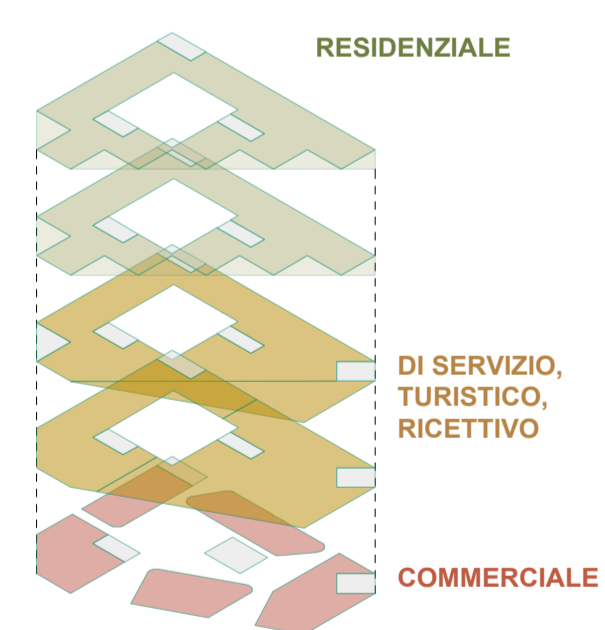
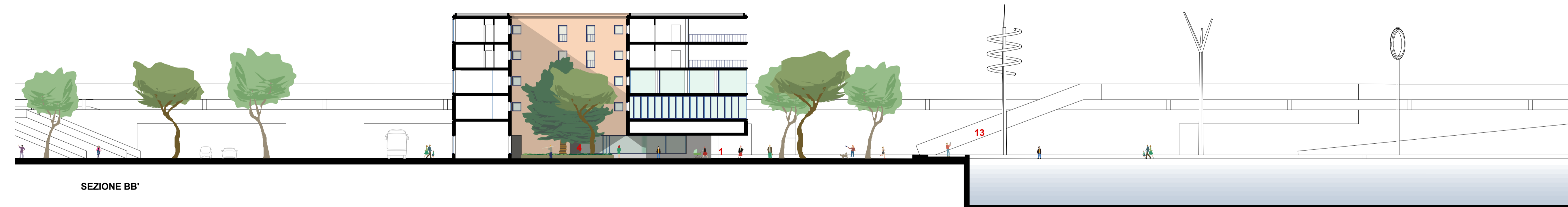
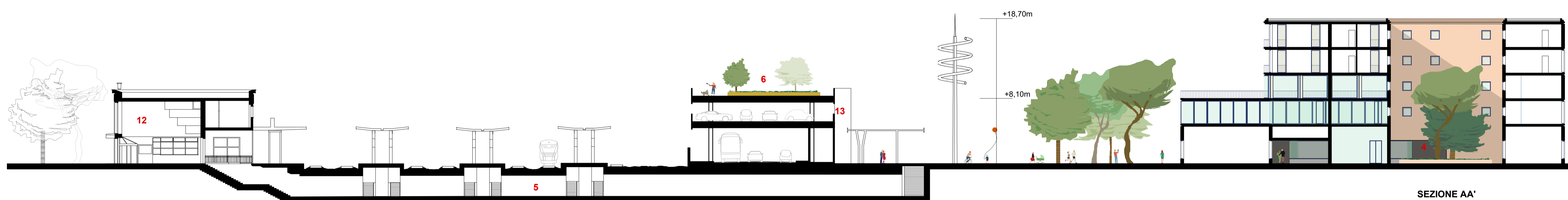
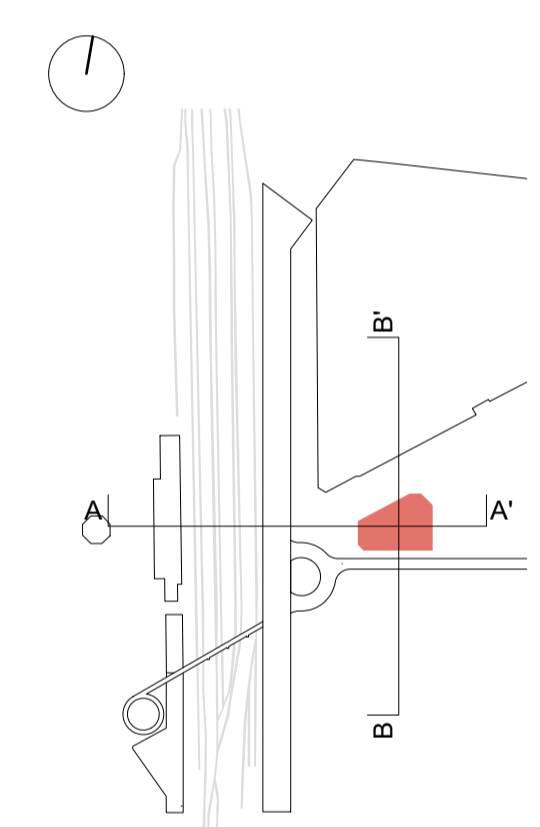
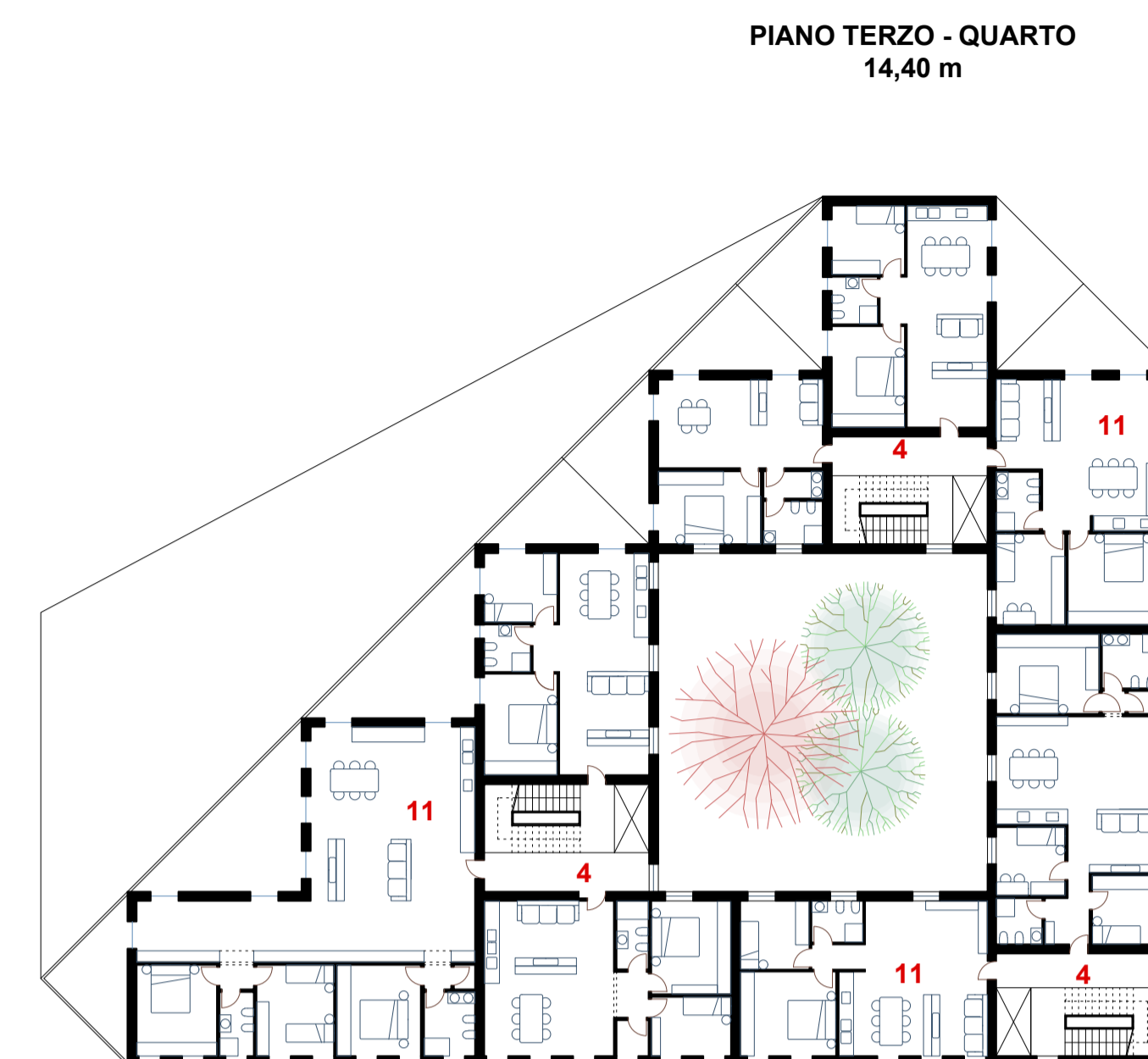
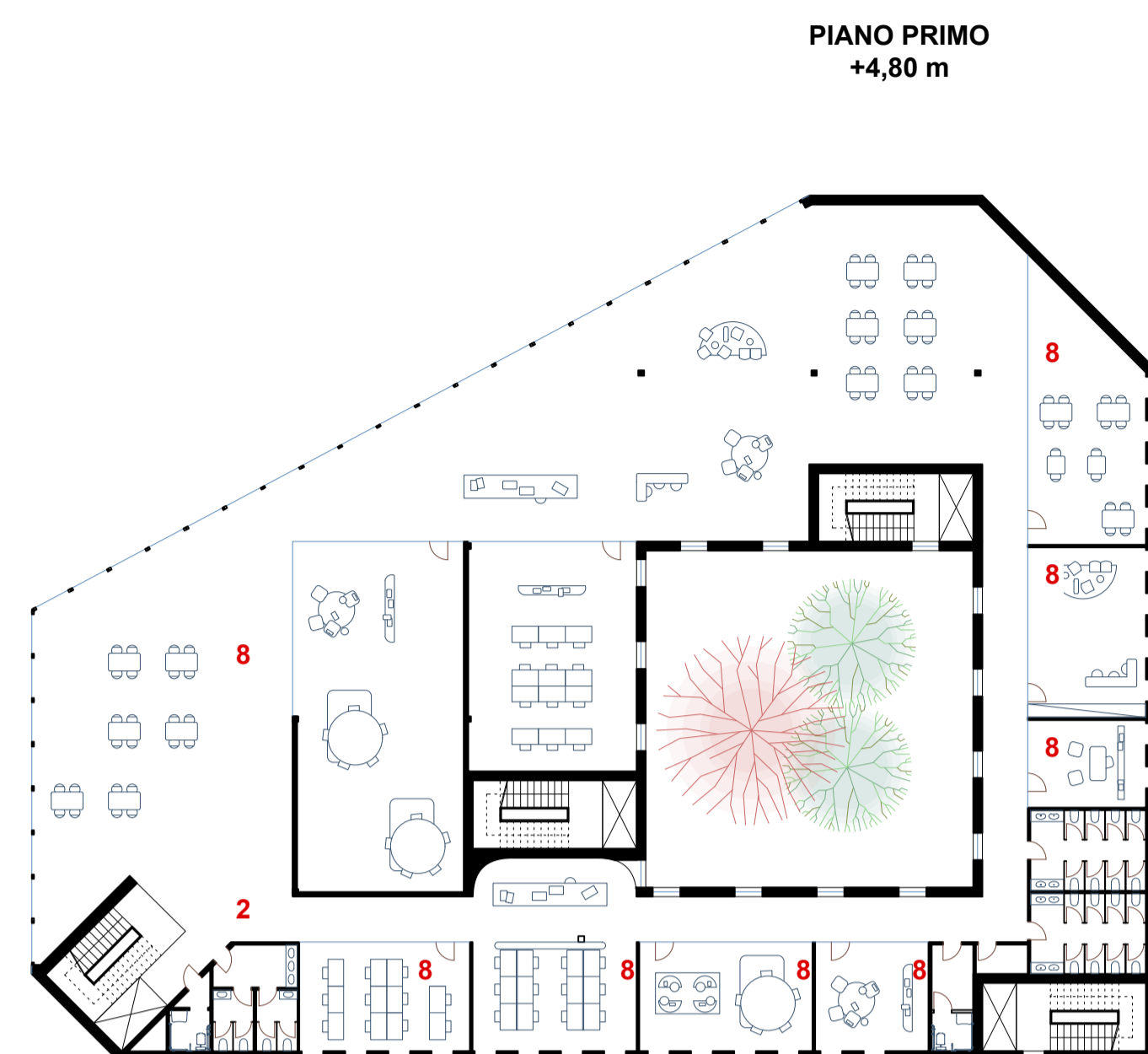
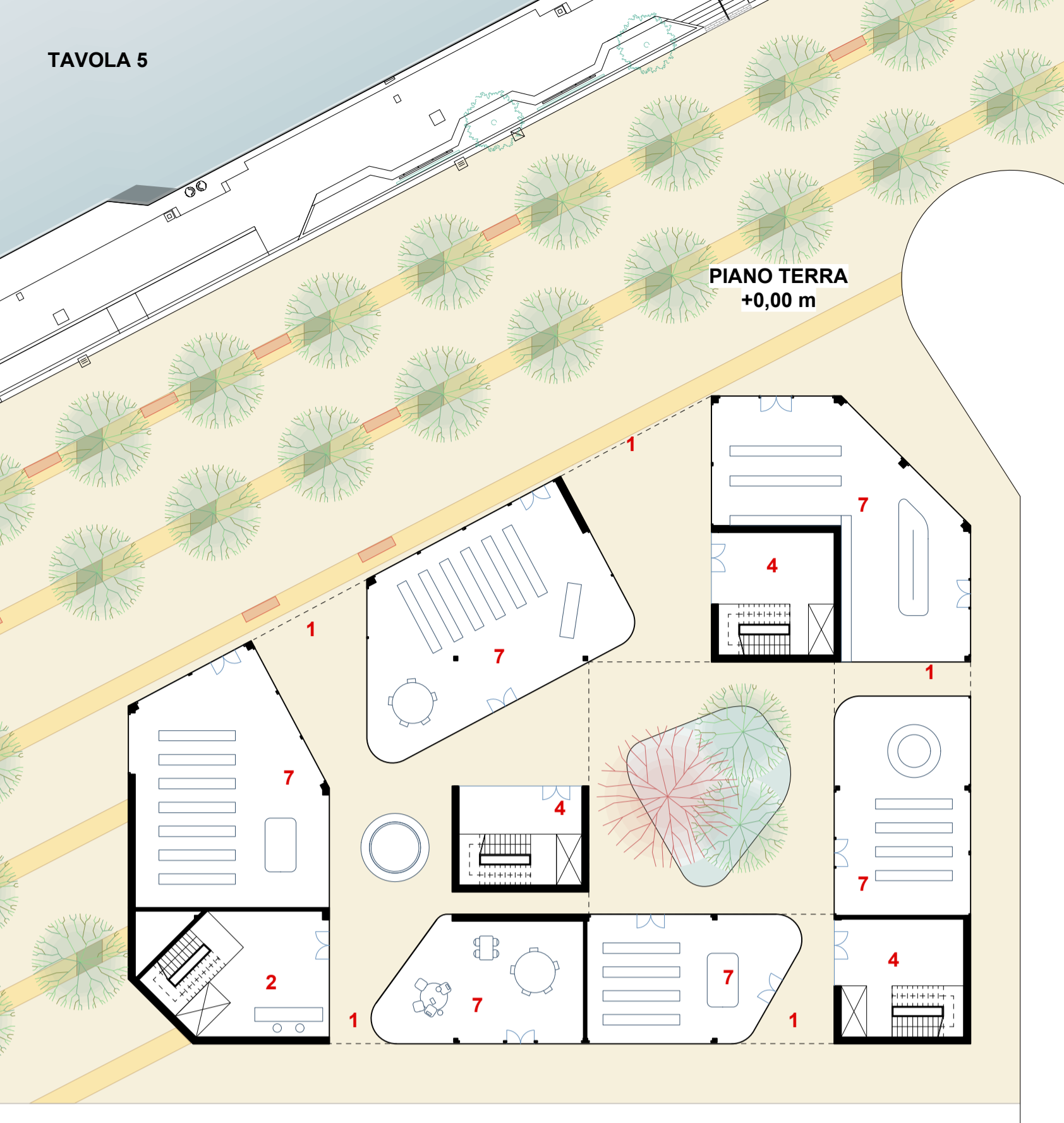

PROSPETTO SUD



PROSPETTO EST



PROSPETTO NORD-OVEST

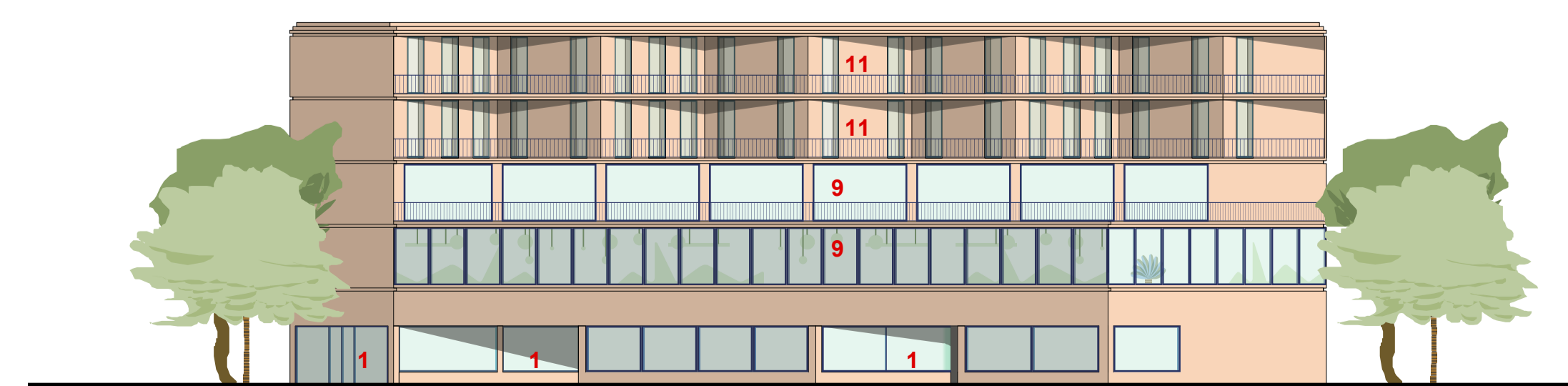

1 ingresso commerciale 2 ingresso direzionale 3 ingresso turistico / ricettivo 4 ingresso residenziale 5 sottopasso urbano stazione - Piazza Darsena 6 parcheggio / Belvedere 7 spazi commerciali 8 direzionale 9 turistico / ricettivo 10 terrazza 11 residenziale 12 stazione 13 scale e ascensori di collegamento Piazza Darsena - parcheggio - Belvedere